

ROME 90 ISLAND - BLACK FASCIA



BLACK GLASS FASCIA
(FRONT & REAR PANEL)

Product Features

| | |
|-----------------------------|--|
| Hood Mounting | Island Hung |
| Cooking Coverage | Suits 75cm - 100cm Cooking Surfaces |
| Filtration | S-Flow Baffle Filters 3x (H-25) - Dishwasher Safe |
| Lighting | LED 6x (1.0W) |
| Finish | AISI304 1.0mm High Grade Stainless Steel |
| Controls | LED Backlit 4 Button <i>mastermind</i> Touch Electronic Control with LED Speed Indicator |
| Speed Settings | 3 Speed + Boost Mode |
| Timer Function | Programmable Timer (10min Increments) + Auto Shut Off After 2Hrs Of Inactivity |
| Ducting | 200mm Acoustic Flexi Ducting - Five (5) Meter Length (Supplied only with Remote Motors) |
| Hood Width | 900mm |
| Hood Depth | 600mm |
| Hood Height (Fascia) | 75mm |

Filtration Zone

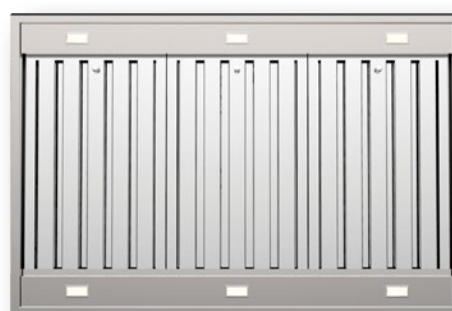

Dimensioned Drawing

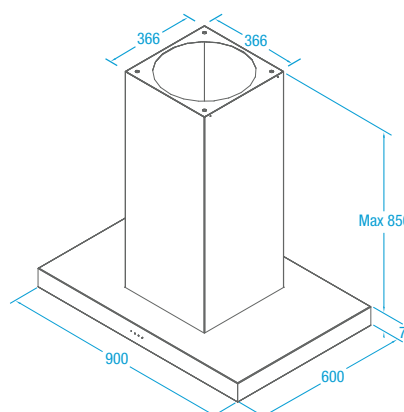

Model / Extraction Unit Selection

| | | | |
|---------------------|--------------------|--|---|
| X7R09S5.IP | Island Hung Canopy | KleenAir Pro Remote Fan Solution - 1140 m³/hr | Remote Inline Motor System |
| X7R09S5.EP | Island Hung Canopy | KleenAir Pro Remote Fan Solution - 1140 m³/hr | Remote External (Roof or Wall Mounted) Motor System |
| X7R09S5.EPP | Island Hung Canopy | KleenAir Pro Plus Remote Fan Solution - 2010 m³/hr | Remote External (Roof or Wall Mounted) Motor System |
| X7R09S5.OP/T | Island Hung Canopy | KleenAir Power On Board Fan Solution - 1020 m³/hr | On-Board Motor System - Top Ducted (150mm Outlet) |
| X7R09S6.OU/T | Island Hung Canopy | KleenAir Ultra EC On Board Fan Solution - 1680 m³/hr | On-Board Motor System - Top Ducted (Inc. Transition Duct) |