

VIENNA 90 ISLAND



Product Features

Hood Mounting	Island Hung
Cooking Coverage	Suits 75cm - 100cm Cooking Surfaces
Filtration	S-Flow Baffle Filters 3x (H-25) - Dishwasher Safe
Lighting	LED 6x (1.0W)
Finish	AISI304 1.0mm High Grade Stainless Steel
Controls	LED Backlit 4 Button <i>mastermind</i> Electronic Control with LED Speed Indicator
Speed Settings	3 Speed + Boost Mode
Timer Function	Programmable Timer (10min Increments) + Auto Shut Off After 2Hrs Of Inactivity
Ducting	200mm Acoustic Flexi Ducting - Five (5) Meter Length (Supplied only with Remote Motors)
Hood Width	900mm
Hood Depth	600mm
Hood Height (Fascia)	120mm



Filtration Zone

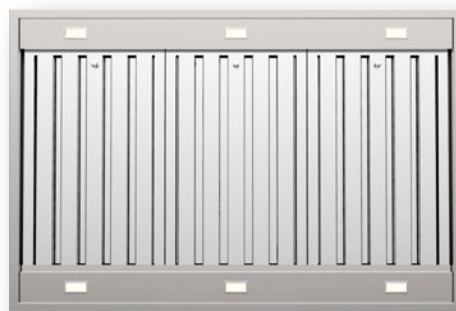

Dimensioned Drawing

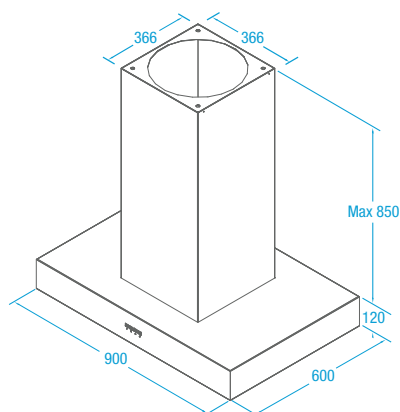

Model / Extraction Unit Selection

X7V09S5.IP	Island Hung Canopy	KleenAir Pro Remote Fan Solution - 1140 m³/hr	Remote Inline Motor System
X7V09S5.EP	Island Hung Canopy	KleenAir Pro Remote Fan Solution - 1140 m³/hr	Remote External (Roof or Wall Mounted) Motor System
X7V09S5.EPP	Island Hung Canopy	KleenAir Pro Plus Remote Fan Solution - 2010 m³/hr	Remote External (Roof or Wall Mounted) Motor System
X7V09S5.OP/T	Island Hung Canopy	KleenAir Power On Board Fan Solution - 1020 m³/hr	On-Board Motor System - Top Ducted (150mm Outlet)
X7V09S6.OU/T	Island Hung Canopy	KleenAir Ultra EC On Board Fan Solution - 1680 m³/hr	On-Board Motor System - Top Ducted (Inc. Transition Duct)