

### Product Features

<b>Hood Mounting</b>	Alfresco Built In (Under Mount)
<b>Cooking Coverage</b>	Suits 150cm - 200cm Cooking Surfaces
<b>Filtration</b>	S-Flow Baffle Filters 5x (H-25) - Dishwasher Safe
<b>Lighting</b>	LED 8x (1.0W)
<b>Finish</b>	<b>AISI316 1.2mm</b> High Grade Stainless Steel
<b>Controls</b>	LED Backlit 4 Button <i>mastermind</i> Electronic Control with LED Speed Indicator with Remote Controller
<b>Speed Settings</b>	3 Speed + Boost Mode
<b>Timer Function</b>	Programmable Timer (10min Increments) + Auto Shut Off After 2Hrs Of Inactivity
<b>Ducting</b>	200mm Acoustic Flexi Ducting - Five (5) Meter Length (2x Supplied)
<b>Hood Width</b>	1960mm
<b>Hood Depth</b>	<b>480mm</b>
<b>Hood Height (Fascia)</b>	330mm (Plus 25mm Top Outlet)

### Filtration Zone



### Dimensioned Drawing

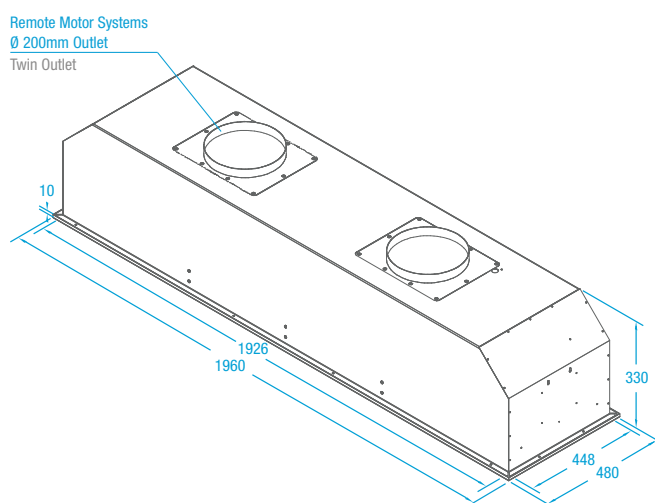









Wireless Remote Control Included

### Model / Extraction Unit Selection

**X3W20S5.2EPP S** Alfresco Built In Hood "Twin" KleenAir **Pro Plus** Remote Fan Solution - **2010 m<sup>3</sup>/hr** Remote **External** (Roof or Wall Mounted) Motor System

S Special Order - Delivery Time Approx. 8 weeks from Order.